



HydrauWinch 80S

Features

- 80 mton winch
- DNV 2.7-3 certified spreader bar with slings and shackles
- Driven by four high torque hydraulic motors through pinion/gear transmission
- Hydraulic valve block ensures safe operation
- Offshore certified lifing lugs acc. DNV 2.7-3 and EN 12079
- Each hydraulic motor is equipped with displacement shift

Benefits

- 24/7** 24/7 (de)mobilisation, installation and commissioning
-  Guaranteed flexibility and high availability
-  Maintenance during the project
-  Clear budget and manageable costs

Specifications HW80S

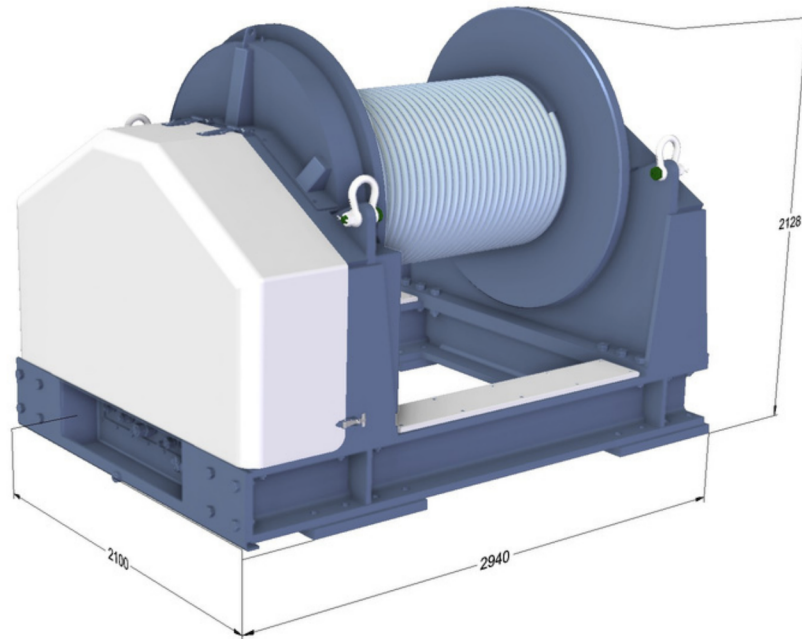

Specifications		
Total weight excl. wire	13 600	kg
Drum diameter	812	mm (ungrooved)
Drum length	1480	mm
Operational temperature	-20 to +50	°C
Technical specifications		
Max. line pull @ low speed	80	mton
Max. line pull @ high speed	32	mton
Max. brake holding capacity	100	mton
Max. line speed @ max. pull	8	m/min
Max. line speed @ high speed	20	m/min
Hydraulic supply	300	l/min
	300	bar
Max. hydraulic pressure	350	bar
Max. wire diameter	48	mm
Pressure (P)	30 S	
Return oil (T)	42 L	
Drain (D)	28 L	
Drain (Y)	22 L	
Pilot (X)	16 S	
Flush (F)	25 S	
Load sense (LS)	12 L	
Power supply nominal		24 VDC, 10 A
Power receptacle		Marechal DSN24, male, 23P + E