

HydrauPack 45E Ex

Features

- Stackable electric driven hydraulic power unit
- Marked with CE Ex II 2G IIB T4 Suitable for use in zone 1
- Offshore-certified rigging acc. DNV 2.7-1 & integrated forklift-trays
- For use in potentially explosive atmospheres (ATEX)
- Certified acc. European Directive 94/9/EC ATEX
- Combinable with other HP45E Ex units and HydrauSupport 1000T

Benefits

- 24/7** 24/7 (de)mobilisation, installation and commissioning
-  Maintenance during the project
-  Guaranteed flexibility and high availability
-  Clear budget and manageable costs

Specifications HP45E Ex

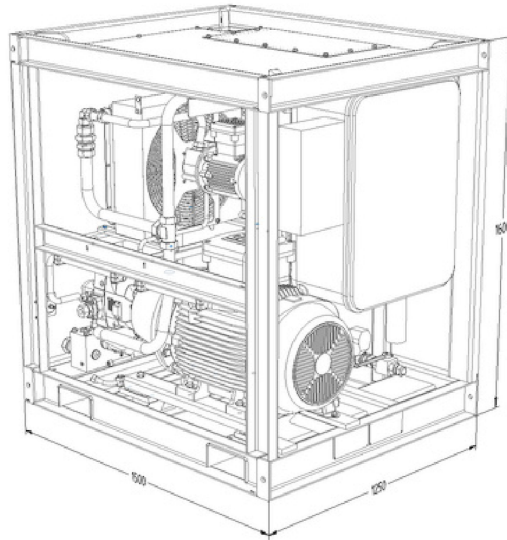

Performance HydrauPack 45E Ex

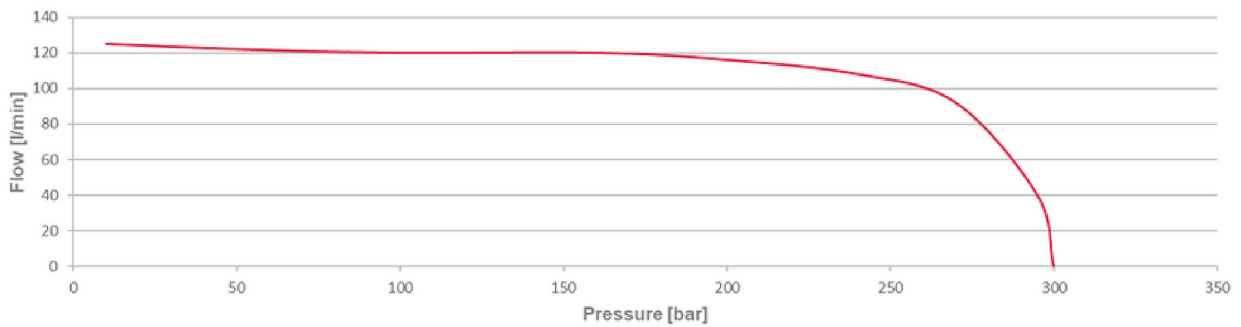

Specifications		
Total weight excl./incl. oil	1900 / 2250	kg
Hydraulic oil tank capacity	380	liter
Operational temperature	-15 to +50	°C
Technical specifications		
Max. working pressure	310	bar
Max. output flow	130	liter/min @ 50 Hz
	155	liter/min @ 60 Hz
Electric motor power	45	kW @ 400 VAC (50 Hz)
	53	kW @ 440 VAC (60 Hz)
Power supply nominal	400	VAC (50 Hz) - 125A (3P + E)
	440	VAC (60 Hz) - 125A (3P + E)
Pressure (P)	30 S	
Return (T)	42 L	
Drain (D)	28 L	
Load sense (LS)	12 S	
Flush (F)	16 S	