



HydrauPack 200F

Features

- Diesel driven stackable hydraulic power unit
- Intelligent electronic control system
- Lloyd's Register offshore certified acc. to DNV rules 2.7-1 CSC and EN12079 incl. rigging
- Combinable with other HP200F units for higher output flow
- Pressure-, flow- and load sense control
- Combinable with HydrauSupport 4500T for higher oil tank volume

Benefits

24/7

24/7 (de)mobilisation, installation and commissioning



Maintenance during the project



Guaranteed flexibility and high availability



Clear budget and manageable costs

Specifications HP200F

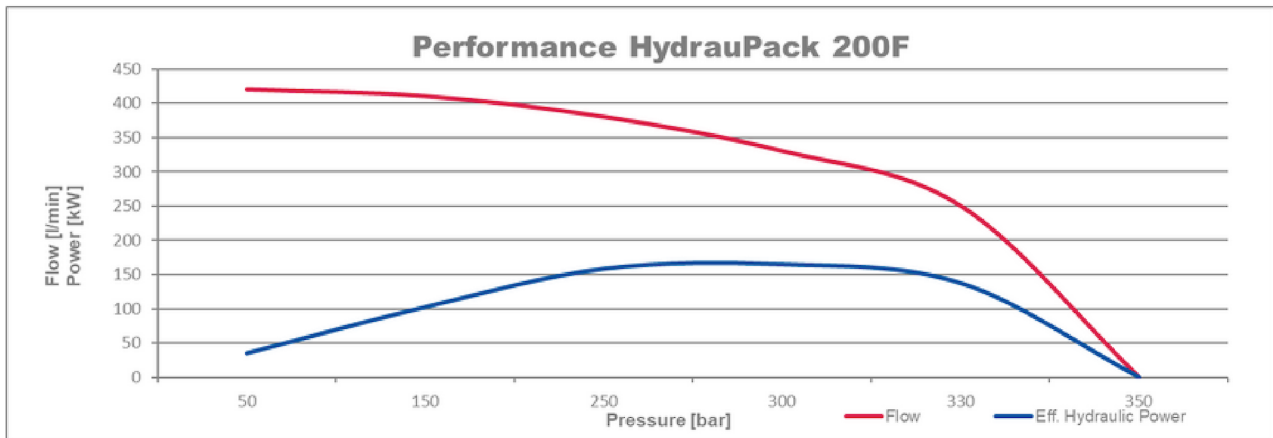
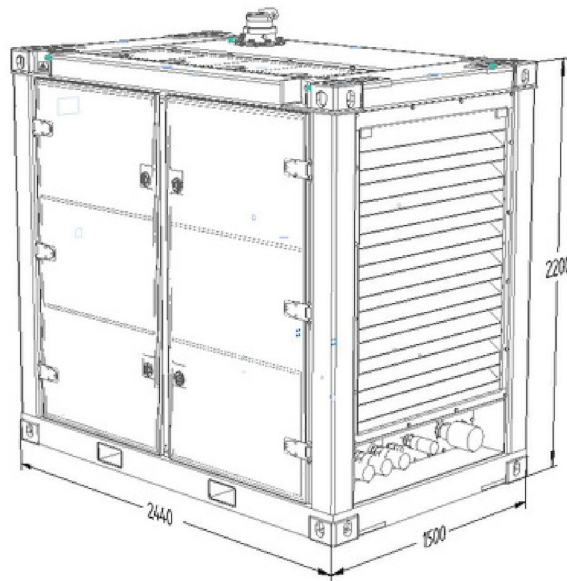

Specifications		
Total weight excl./incl. oil	4800 / 5825	kg
Hydraulic oil tank capacity	700	liter
Operational temperature	-20 to +50	°C
Technical specifications		
Max. working pressure	350	bar
Max. output flow	450	liter/min
Max. output flow @ 350 bar	270	liter/min
Total engine power	205 or 224	kW @ 1800 rpm (25 °C)
Effective hydraulic power	approx. 170	kW (25 °C) approx.
Cooling capacity air/oil	90	kW @ ΔT = 40 °C
Hydraulic fluid	H(V)LP ISO VG 46, 68	
Pressure (P)	Q.C. snap-tite series 75, 2" (male)	
Return (T1 + T2)	2 pcs. Q.C. Tema T20020, 2" (male)	
Return spare (T3)	G2" (plugged)	
Drain (D)	Q.C. Tema T15020, 1-1/2" (male)	
Load sense (LS)	12 S	
Filling point	Q.C. flat face acc. ISO 16028, 1/2" (male)	