



HydrauPack 100

Features

- Diesel-driven hydraulic power unit
- Sound-insulated
- Integrated hydraulic oil cooler
- Flush connection
- Pressure and load sense control with external connection
- Provided with lifting lugs and integrated forklift-trays

Benefits

24/7

24/7 (de)mobilisation, installation and commissioning



Guaranteed flexibility and high availability



Maintenance during the project



Clear budget and manageable costs

Specifications HP100

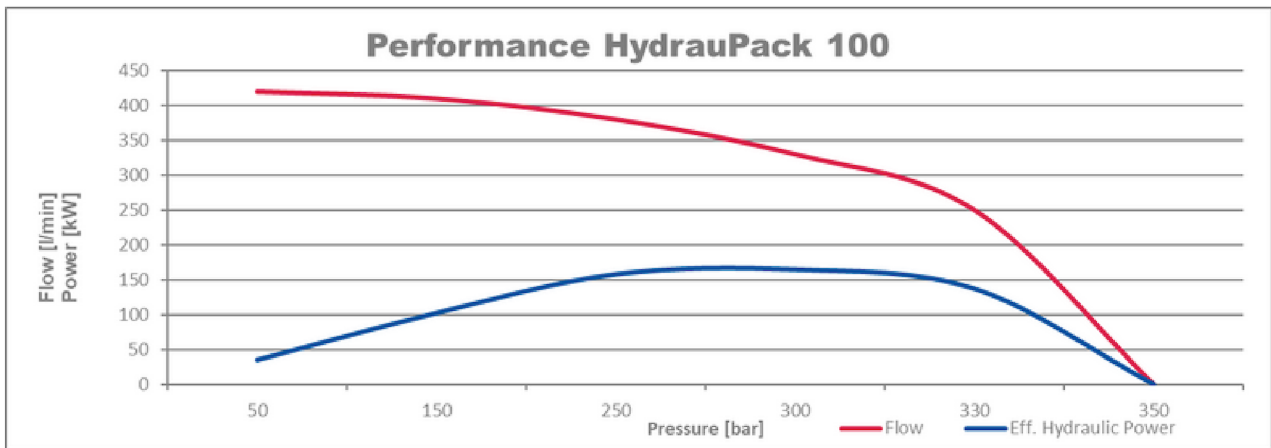
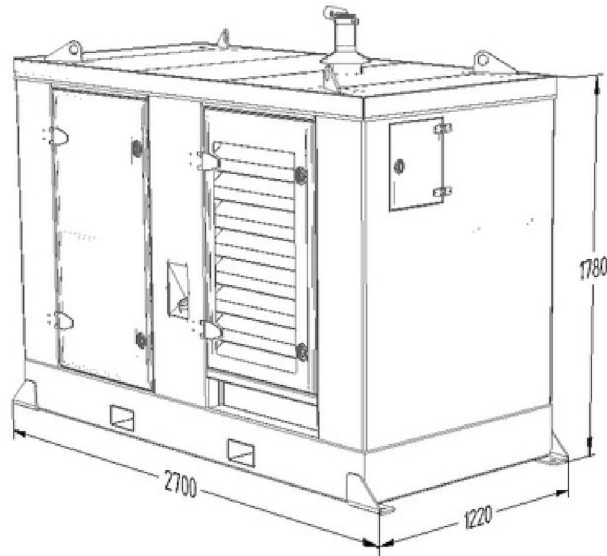

Specifications		
Total weight excl./incl. oil	2520 / 3125	kg
Hydraulic oil tank capacity	450	liter
Fuel tank capacity	250	liter
Operational temperature	-15 to + 55	°C
Technical specifications		
Max. working pressure	420	bar
Nominal working pressure	350	bar
Max. output flow	210	liter/min up to 225 bar
Output flow @ nom. working pressure	135	liter/min
Output flow @ max. working pressure	110	liter/min
Total engine power	104	kW (25 °C)
Effective hydraulic power	Approx. 80	kW (25 °C)
Pressure (P)	38 S	
Return (T)	42 L	
Drain (D)	28 L	
Load sense (LS)	12 S	
Flush (F)	16 S	